

Paal-Knorr reaction in a continuous flow microreactor

Background

The synthesis of pyrroles through the Paal-Knorr reaction is a useful reaction in organic chemistry, as the starting materials react almost instantaneously without formation of byproducts. Traditionally, this reaction is very difficult to control due to its fast reaction rate and exothermic character. In large-scale batch synthesis, the Paal-Knorr reaction is therefore replaced by other methods to synthesise pyrroles.

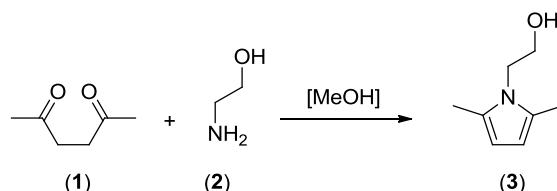

Figure 1: Paal-Knorr reaction scheme

Using continuous flow chemistry, the Paal-Knorr reaction is suitable for large-scale, preparative synthesis of (substituted) pyrroles. The latter has the added advantage of handling all toxic and corrosive reagents inside a closed system. In continuous flow, a 1,4-diketone (1) and a primary amine (2) are introduced into the microreactor, where they react to form the corresponding pyrrole (3).

Setup and method

Material

- FlowStart B-200
- B-230 Pump Module
- B-242 Inlet Module
- 3x plastic 10 mL syringe
- Basic Quench Microreactor (internal volume $V_{\mu R} = 92 \mu\text{L}$)

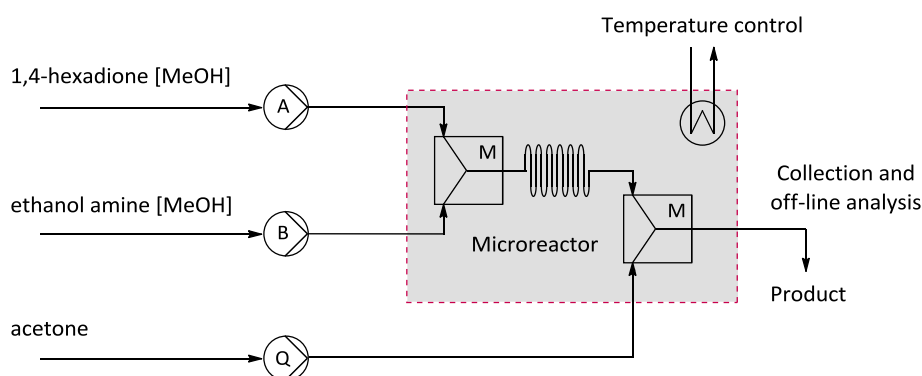

Figure 2: FlowStart setup for the Paal-Knorr reaction

Chemicals

Recommended grade: *pro analysi* (p.a.) or *reagent grade*.

- 2,5-Hexadione (also called: acetyl acetone)
- Ethanol amine
- Methanol
- Acetone
- 2-Bromotoluene (used as internal standard)

Stock solutions

- A. 2,5-Hexadione/2-bromotoluene/methanol (9:1:10 v/v; corresponding to 3.84 M)
- B. Ethanol amine/methanol (1:1 v/v; corresponding to 8.28 M)
- Q. Acetone (corresponding to 13.64 M)

Stock solutions are to be prepared at the beginning of the experiments. Make sure to close the flasks which are used to store the solutions, as some of the components are rather volatile.

Analysis

Analysis of the reaction mixture is done using gas chromatography. Calibration of the product against the internal standard (2-bromotoluene) is done using general methodology. For a quick calibration, make 4 samples with a fixed 2-bromotoluene concentration and a varying substrate concentration. Analyse these samples and 1) setup a calibration curve of peak area ratio against concentration ratio and/or 2) determine the relative response factor.

Optimisation experiment

The goal of this experiment is to identify the influence of reaction parameters on product yield and/or to find optimal reaction conditions (i.e. parameter settings) for performing the Paal-Knorr synthesis using flow chemistry. Optimisation in a three-dimensional space can be done using various mathematical techniques, of which are commonly used: univariate analysis, full-factorial design, 3D simplex.

Flow parameters

Using flow chemistry, reaction parameters can be easily varied by adjusting the flow rates and temperature. The latter parameter speaks for itself, while both B/A molar excess ratio and reaction time are controlled by setting different flow rates. The reaction parameters and their useful ranges are listed in Table 2. Parameters should not be chosen outside these ranges, as the pump's flow rate and the substrate's boiling point impose some of these limits. Also, the reaction has been extensively screened to yield a good experimenting region within these limits.

Table 1: Reaction parameter ranges

Parameter	Minimum value	Maximum value
Reaction time (t_R)	10 sec	180 sec
Amine/diketone molar excess ratio ($ME_{B/A}$)	0.8	8.0
Temperature (T)	20°C	85°C

The stabilisation time for this reaction is two times the reaction time. The target volume of solution A to be collected is 100 μ L, all samples are collected in a GC vial containing 800 μ L acetone. Quenching molar excess ratio ($ME_{Q/B}$) is fixed to 5.0. The used setup can be seen in Figure 2.

Paal-Knorr optimisation setup

Preparation:

- Using one of the above optimisation techniques (or a different one), choose the parameter sets you want to investigate.
- For all the points in the parameter sets, calculate the flow rates and collection time. Then conduct the experiments in the same way as the introductory experiment. However, stabilisation time is changed from 10 minutes to two times the reaction time ($t_{stab} = 2 \cdot t_R$).
- If you have obtained all measurement data and the results look valid (e.g. duplicates show the same yield), present your data graphically and find the optimal conditions to perform the Paal-Knorr pyrrole synthesis in flow.

Analysis:

- Measure the samples using GC, analyse the yield per sample, and report the obtained data in a graphical way. Also, find *optimal conditions* and/or *parameter trends* for performing the Paal-Knorr reaction in flow.

Questions

1. **Preparation of the experiment:**
 - a. Roughly calculate the cost of the experiment from the prices of the chemicals. In other words, calculate the price (e.g. per gram) of the pyrrole product.
 - b. Find the safety aspects (R/S values) of the used chemicals.
2. **Q: Find the reaction mechanism for the Paal-Knorr reaction, and show the essential (sequential) steps from diketone and amine to the pyrrole product. (Note: there is still some debate on what the actual mechanism is, so multiple answers are plausible.)**
3. **Q: What advantages in performing the Paal-Knorr reaction in continuous flow can you think of? Also, can you think of any disadvantages?**