

Wittig reaction in a continuous flow microreactor

Background

A convenient and selective way of forming a carbon-carbon double bond is through the Wittig reaction and its modifications. Although easily performed in batch, the Wittig reaction could be incorporated in a total synthesis using continuous flow. The latter has the added advantage of handling all toxic and corrosive reagents inside a closed system.

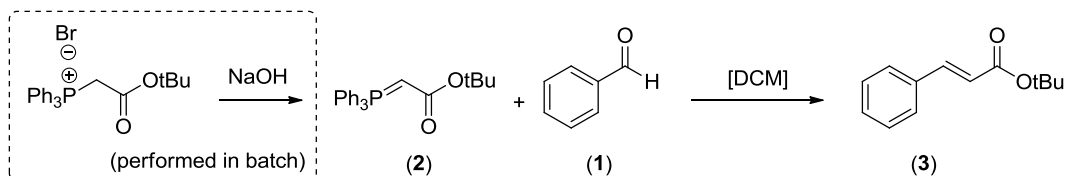

Figure 1: Wittig reaction scheme

The phosphonium ylide reagent is prepared in batch, by deprotonation of the corresponding Wittig salt. In continuous flow, an aldehyde (1) and a phosphonium ylide (2) are introduced into the microreactor, where they react to form the corresponding unsaturated Wittig product (3). The Wittig reaction is an example of a very selective reaction, producing no side products. However, the formed double bond can take two configurations: the *cis* (Z) and the *trans* (E) form. The latter is shown in Figure 1.

Setup and method

Material

- FlowStart B-200
- B-230 Pump Module
- B-242 Inlet Module
- Basic Quench Microreactor (internal volume $V_{\mu R} = 92 \mu\text{L}$)

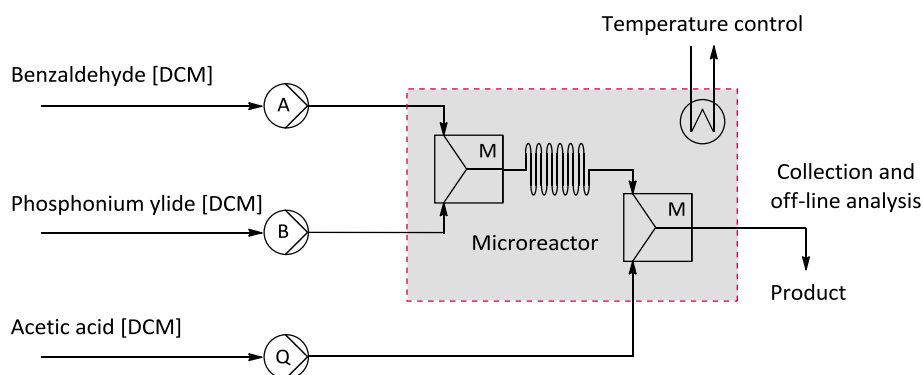

Figure 2: FlowStart setup for the Wittig reaction

Chemicals

Recommended grade: *pro analysi* (p.a.) or *reagent grade*.

- tert-Butoxycarbonylmethyl phosphonium bromide (Wittig salt)
- benzaldehyde

- sodium hydroxide (0.2 M solution)
- acetic acid
- dichloromethane (DCM)
- anisole (used as internal standard)

Stock solutions

- A. Benzaldehyde (102 μL , 1.00 mmol) and anisole (109 μL , 1.00 mmol) dissolved to a total volume of 10 mL with dichloromethane (corresponding to 0.1 M)
- B. Stir 457 mg (1.00 mmol) of the Wittig salt (in 5 mL dichloromethane) with 7.5 mL 0.2 M NaOH for 10 minutes. Separate layers, dry, filter and fill up to a total volume of 10 mL with dichloromethane (corresponding to 0.1 M)
- Q. Acetic acid (1.73 mL, 30.0 mmol) dissolved to a total volume of 10 mL with dichloromethane (corresponding to 3.0 M)

Stock solutions are to be prepared at the beginning of the experiments. Make sure to close the flasks which are used to store the solutions, as some of the components are rather volatile.

Analysis

Analysis of the reaction mixture is done using gas chromatography. Calibration of the product against the internal standard (anisole) is done using general methodology. For a quick calibration, make 4 samples with a fixed anisole concentration and a varying compound concentration. Analyse these samples and 1) setup a calibration curve of peak area ratio against concentration ratio and/or 2) determine the relative response factor.

Basic experiment

To get acquainted with the reaction and with flow chemistry in general, a so-called *basic experiment* is performed. This experiment is the Wittig reaction at fixed parameters – a reaction time (t_R) of 5.0 min, a temperature of 20°C and a phosphonium ylide molar excess ratio ($ME_{B/A}$) of 4.0. The Q/B molar excess ratio ($ME_{Q/B}$) is set to a fixed value of 20. The target volume of solution A to be collected is 20 μL , all samples are collected in a GC vial containing 500 μL dichloromethane. The used setup can be seen in Figure 2.

The corresponding flow rates can be calculated according to the known equations. After preparation of this experiment, the instructor should check if the calculated flow rates and collection time are correct.

Procedure

- Prepare solutions A, B and Q
- Fill the three syringes with solutions A, B and Q
- Slide the microreactor into the holder and connect inlet and outlet tubing
- Connect the inlet tubing to the corresponding syringes, and place the syringes on the pumps
- Set the right flow rates and press start
- Stabilise for 15 minutes
- Collect your sample for the calculated time
- Analyse your sample using gas chromatography and calculate substrate conversion from the calibration curve or relative response factor
- Rinse the *FlowStart* system by purging the tubing and microreactor with acetone
- Empty, clean and dry the syringes afterwards

Note: Make sure to close the vial after collecting. This is done because some of the reaction components are rather volatile and readily evaporate from the vial.

Questions

1. **Preparation of the experiment:**
 - a. Roughly calculate the cost of the experiment from the prices of the chemicals. In other words, calculate the price (e.g. per gram) of the product.
 - b. Find the safety aspects (including R/S values) of the used chemicals.
2. **Q: Find the reaction mechanism for the Wittig reaction, and show the essential (sequential) steps from benzaldehyde and tert-Butoxycarbonylmethyl phosphonium bromide (phosphonium ylide) to Wittig product.**
3. **Q: What advantages in performing the Wittig reaction in continuous flow can you think of? Also, can you think of any disadvantages?**