

Application Note 13.1

Wittig reaction



The Wittig reaction for the synthesis of a cinnamate ester was successfully translated from batch to continuous flow in the *FlowStart* microreactor platform, providing a viable alternative to the conventional batch process.

Introduction

A convenient and selective way of forming a carbon-carbon double bond is through the Wittig reaction and its modifications. Although easily performed in batch, the Wittig reaction could be incorporated in a total synthesis using continuous flow.

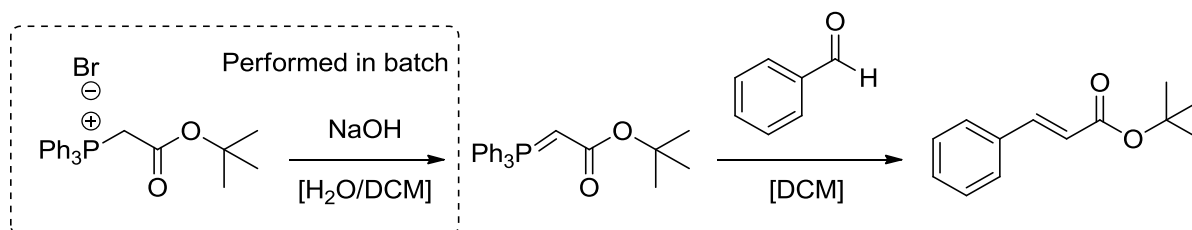

Figure 1: Wittig reaction to form *tert*-Butyl cinnamate

As a feasibility study, FutureChemistry has translated this reaction from a batch process to a continuous flow process. FutureChemistry's typical three-tier approach led to a protocol which can be adapted to any viable substrate:

- 1) Translation of batch process to continuous flow process:
 - a) Stock solutions approach, yielding a homogeneous reaction mixture.
 - b) Quenching solution to follow the reaction in time.
 - c) Flow markers approach to accurately assess reaction parameters.
- 2) Automated reaction optimisation.
- 3) Out scaling to preparative synthesis.

This *application note* describes the translation of the batch process to the continuous flow process using the *FlowStart B-200*.

Batch to flow conversion

In contrast to batch chemistry, reactions in continuous flow are conducted from stock solutions. These solutions should remain inactive after preparation, but react when combined. In the Wittig reaction, solution A contains benzaldehyde and solution B contains the phosphonium ylide. The used flow setup is depicted in Figure 2.

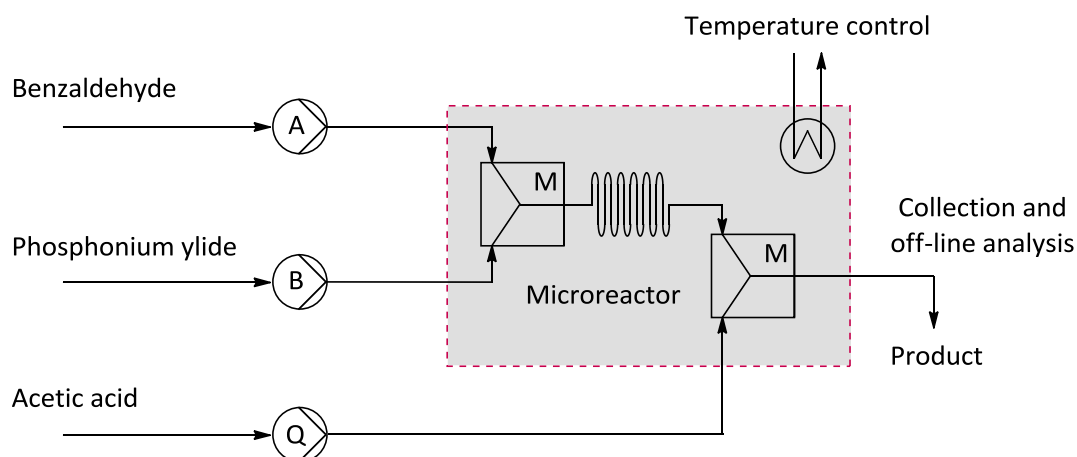

Figure 2: FlowStart setup

To stop the reaction at a certain point in time a quenching agent is needed, which reacts with the reagent many times faster than the reaction itself. In the Wittig reaction, acetic acid is used to force the ylide back to its salt form (acetate).

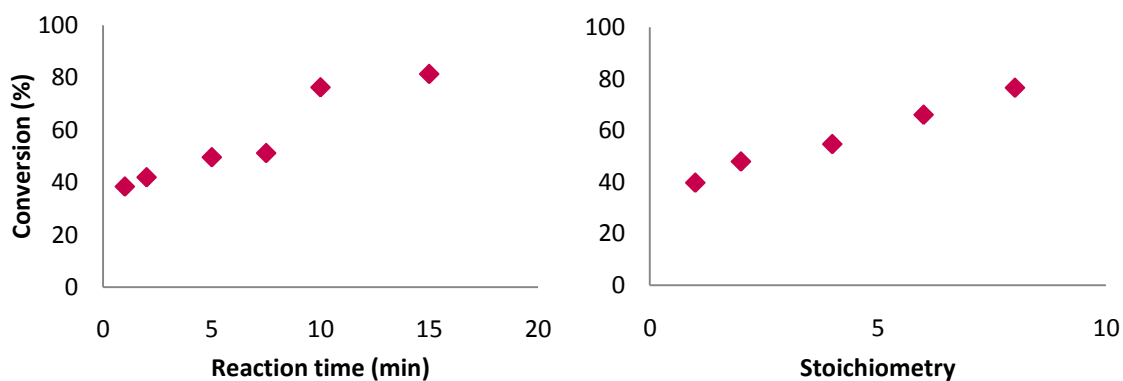

Figure 3: Left: Benzaldehyde conversion vs. reaction time (stoichiometry 4.0, temperature 20°C). Right: Benzaldehyde conversion vs. stoichiometry (reaction time 5.0 min, temperature 20°C).

In the FlowStart experiments, ylide/benzaldehyde stoichiometry and reaction time were varied. With the above parameter values, conversions up to 80% were observed (Figure 3), and the Wittig reaction was successfully converted from batch to flow. The effect of reaction temperature on substrate conversion was found to be minimal.

Method

All experiments were conducted in a standard FutureChemistry B-200 *FlowStart* setup, using the Basic Quench Microreactor with internal volume of 92 μL . Benzaldehyde was used as model substrate.

Solution A (0.1 M): Benzaldehyde (102 μL , 1.00 mmol) dissolved to a total volume of 10 mL with dichloromethane

Solution B (0.1 M): Treat 1.00 mmol of the Wittig salt (in 5 mL dichloromethane) with 7.5 mL 0.2 M NaOH for 10 min. Separate layers, dry, filter and fill up to a total volume of 10 mL with dichloromethane

Solution Q (3.0 M): Acetic acid (1.73 mL, 30.0 mmol) dissolved to a total volume of 10 mL with dichloromethane

Three glass 1.0 mL syringes were loaded with solutions A, B and Q respectively. For each experiment, the desired flow rates were calculated according to the following equations:

$$\text{Total flow} = \text{microreactor volume} / \text{reaction time}$$

$$\text{Flow A} = \text{total flow} / (1 + \text{ylide stoichiometry})$$

$$\text{Flow B} = \text{Flow Q} = \text{Flow A} * \text{ylide stoichiometry}$$

All product mixtures were analysed with GC, with retention times according to Table 1. Analysis was performed on a Shimadzu GC2010 using a Quadrex 007 1701 apolar column (L 15.0 m, ID 0.10 mm) and flame ionisation detector (T 325°C, H₂ 60 mL/min, Air 400 mL/min), using a temperature program (0-0.5 min 60°C, 0.5-2.2 min 60-230°C, 2.2-2.7 min 230°C) and 1.0 μL injection with split ratio 200.

Table 1: GC analysis retention times

Compound	Function	Retention time [min]
benzaldehyde	substrate	1.20
<i>tert</i> -Butyl cinnamate	product	2.10